

## Installation Instructions

### DREX0015 HS-PC

### HeatShrink Power Connection / End Seal



#### APPROVALS\*



Class I, Div. 2, Groups A, B, C, D  
Class II, Div. 2, Groups F, G  
Class III

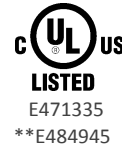

\*This kit is not UL Listed for use with HotTape products.  
\*\* General Purpose/Ordinary Location UL File

These installation instructions are only for use with the following Drexan HeatTracer Self-Regulating heater products:

PipeGuard® Warm (PGW), MultiTrace® (MT) and HotTape® (HT).

#### HEATING CABLE RATINGS

120 – 277 Volt, 3–10 W/ft., maximum 32A.  
Maximum continuous exposure temperature 150°F/65°C.  
Minimum bend radius: 1.18 in. (30 mm) @ 68°F/20°C.  
This kit may be installed in temperatures as low as -40°F/°C.

**CAUTION: A ground fault protection device must be used with this heating device.**

**ATTENTION: Ce produit doit être utilisé avec une protection de mise à la terre**



**WARNING:** This is an electrical device and in order to ensure proper operation and prevent shock or fire it must be installed correctly. Read these important warnings. Follow all installation instructions.

**CAUTION:** Ground-fault equipment protection shall be provided to de-energize all normally ungrounded conductors of electrical heating cable sets, with ground fault settings sufficient to allow normal operation of the heater unless applicable codes permit otherwise, and to minimize the danger of fire from sustained electrical arcing if the heating cable is damaged or improperly installed and to comply with Drexan requirements, agency certifications and National Electrical codes. Conventional circuit breakers may not stop arcing. Each heating device branch circuit or each heating device shall have ground fault equipment protection.

The heating cable core is conductive and can short if not properly insulated and kept dry. Component and heating cable ends must be kept dry before and during installation. Fire-resistant thermal insulation materials should be used.

Heating cable core bus wires can overheat and short when damaged. When cutting the cable jacket or core do not break bus wire strands. Bond the metallic braid of the self-regulating heating cable to a suitable grounding (earth) terminal. De-energize before installation or servicing.

Where equipment may be installed in locations where it may be subject to damage, or exposed to excessive external stresses (e.g. vibration, heat, impact) or aggressive substances, it must be protected by additional means. Any repairs or parts replacement must be done by Drexan or appointed agents. Substitution of parts, or utilization in a manner not specified by Drexan may impair equipment protection and void warranty, approvals and performance claims. Do not use substitute parts or the use of electrical tape. Component approvals and performance characteristics are based on Drexan specific parts only.

© Drexan Energy Systems Inc.  
Kelowna, BC, Canada, V4V 1S5

## KIT CONTENTS

- Strain Relief (cap, washer, grommet, base)
- (3) Wire Nuts
- Black heat shrink tube 1" (25 mm)
- (2) Warning Labels
- Installation Instructions
- Lock Nut and Sealing Ring
- Green/yellow heat shrink tube 6" (15 cm)
- (2) Black heat shrink tubes 5.5" (14 cm)
- End Seal Kit (DREX0017 (HS-ESK))

## REQUIRED BUT NOT PROVIDED

### Materials

- Certified Junction Box for suitable location

### Equipment

- Utility Knife
- Wire Stripper
- Wire Cutter
- Crimp Tool
- Multi-head Screwdriver
- Needle Nose Pliers
- Heat Gun
- Pipe Wrench

## ASSEMBLY INSTRUCTION DETAILS – POWER CONNECTION

1. Slide parts onto cable as shown.

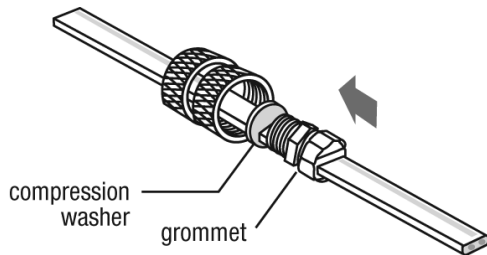

2. Lightly score around and down the outer jacket. Bend heating cable to break jacket at score and peel off outer jacket.

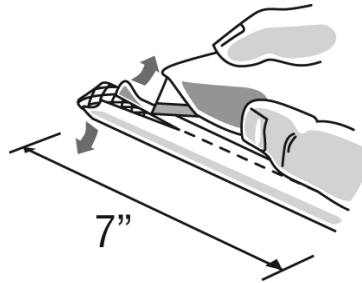

3. Push back Braid to loosen. Spread apart Braid as shown and bend the heating cable and work it through the opening in the Braid.

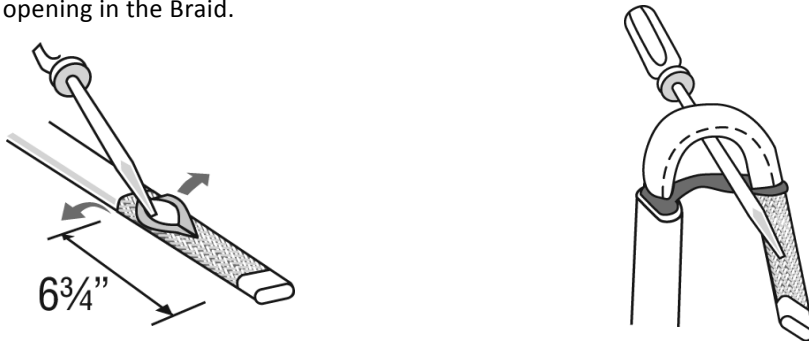

4. Position Braid on one side of the heating cable and twist into a pigtail. Lightly score around and down the inner jacket and clear membrane and remove.

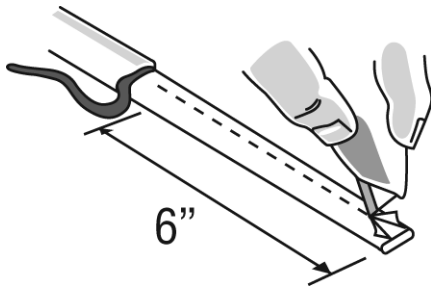

5. Notch at core end, twist back and peel bus wires from core.

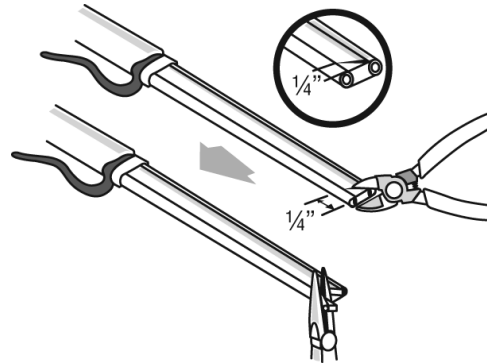

6. Score between bus wires at the base of the jacket, bend core to break free jacket base. Remove any remaining core material from bus wires.

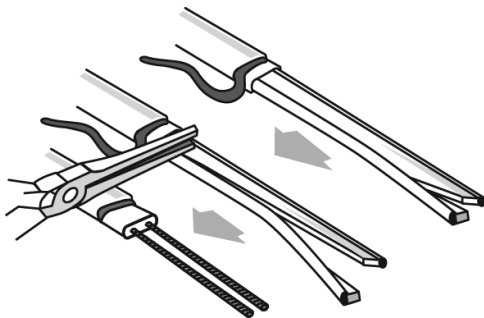

7. Slide heat shrink tubes into place against conductive core. Shrink tubing, moving side to side carefully to ensure the tube is not scorched.

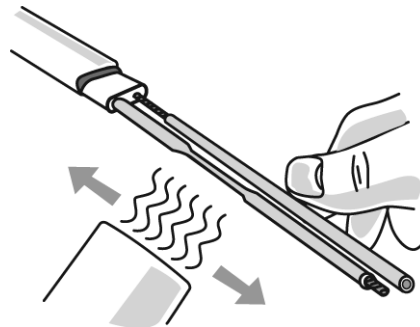

8. Slip green/yellow heat shrink tube over the braid and shrink carefully, do not to scorch the tube.

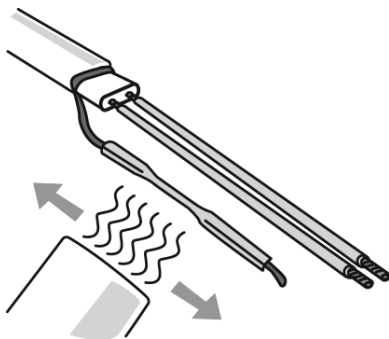

9. Center 1" shrink tube over the end of the heating cable as shown. Heat the tube evenly until it shrinks and the adhesive flows from both ends. Pinch with pliers while still hot and **hold for 15 seconds** to ensure seal.

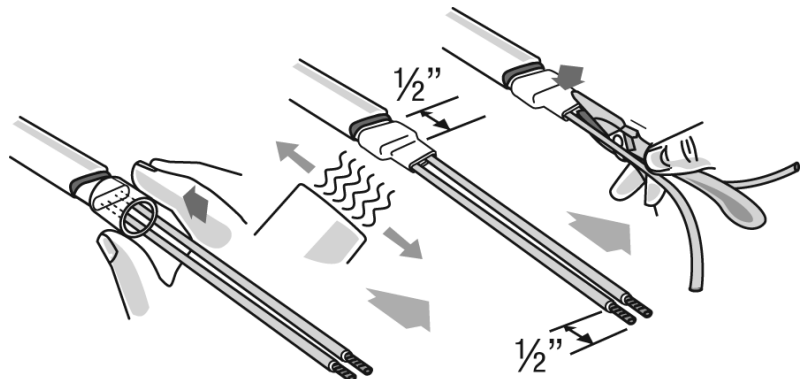

10. Slide parts into position as shown.

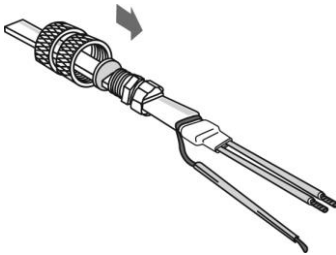

11. Install the strain relief in a Listed junction box. Ensure the sealing ring is compressed between strain relief body and junction box surface. Make connections using wire nuts provided and ensure the strain relief and lock nut are grounded. When installing into a non-metallic junction box, a UL-Listed bonding locknut shall be used and an additional conductor shall be provided to bond the locknut, cable braid and branch circuit ground conductor.

For installation in hazardous locations the junction box and (if used) the termination fittings provided for field wiring shall comply with the requirements for boxes and fittings of the National Electrical Code or Canadian Electrical Code (as applicable) for the hazardous classification of the installation. Wiring methods shall comply with one of the wiring methods permitted in the NEC or CEC (as applicable) for the hazardous location classification of the installation.

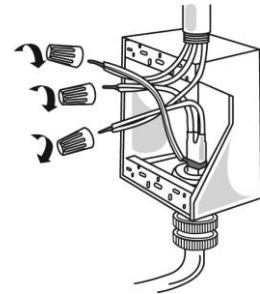

### ASSEMBLY INSTRUCTION DETAILS – END SEAL (DREX0017)

- Strip outer jacket  $\frac{3}{4}$ " (19 mm) as shown. **Do not cut into inner jacket.**
- Unravel Ground Braid and trim outer jacket cut back.

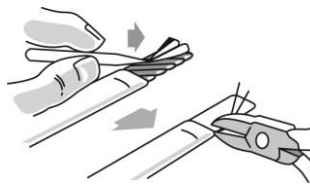
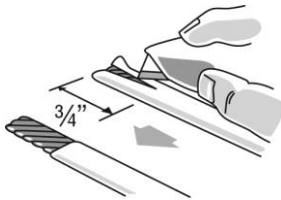

- Heat shrink tubing in place with  $\frac{3}{8}$ " (10 mm) over end of heating cable. Remove heat and squeeze with needle-nose pliers. **Hold for 15 seconds.**

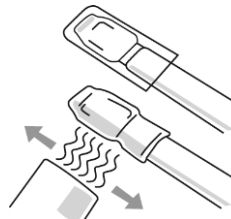
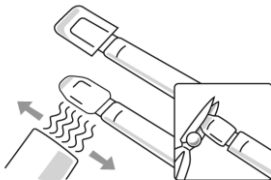

- Heat shrink cap in place over smaller heat shrink tube until inner sealant starts to appear out from the boot edge.