

DC-AS4

4 Circuit Digital Controller

Installation & User Guide

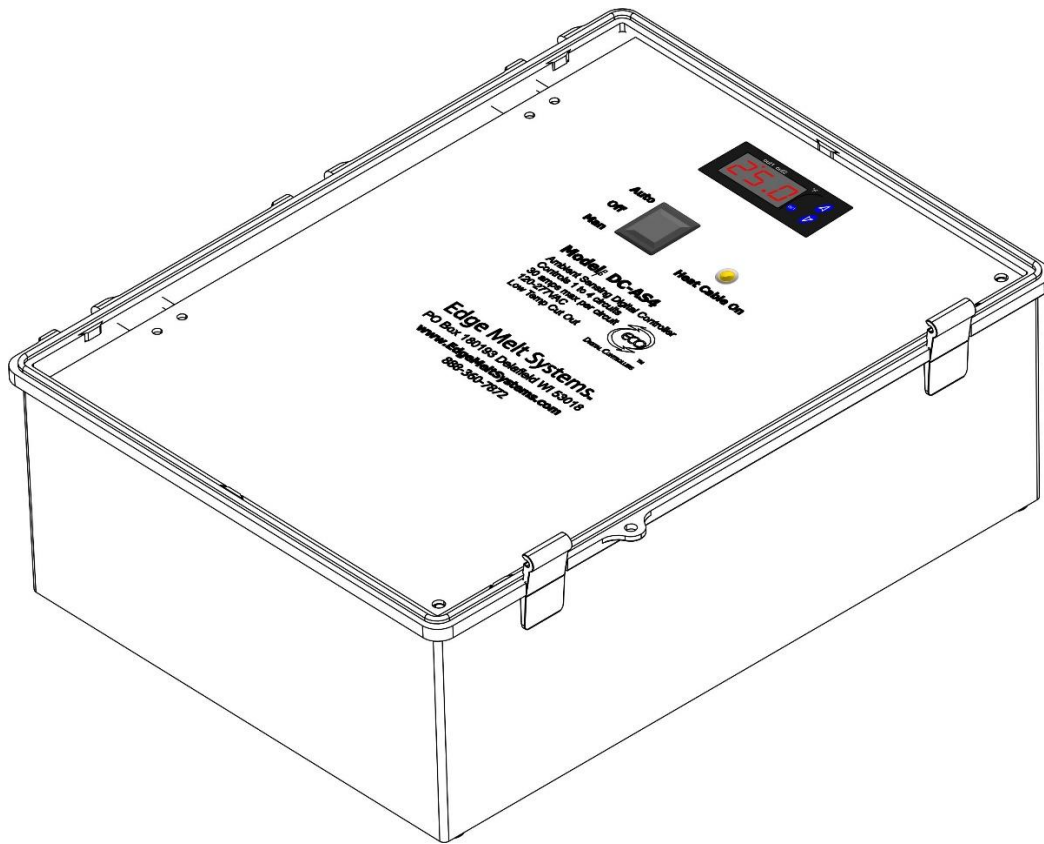

EdgeMeltSystems™

Roof Ice Prevention Perfected

Version 1.1

Overview

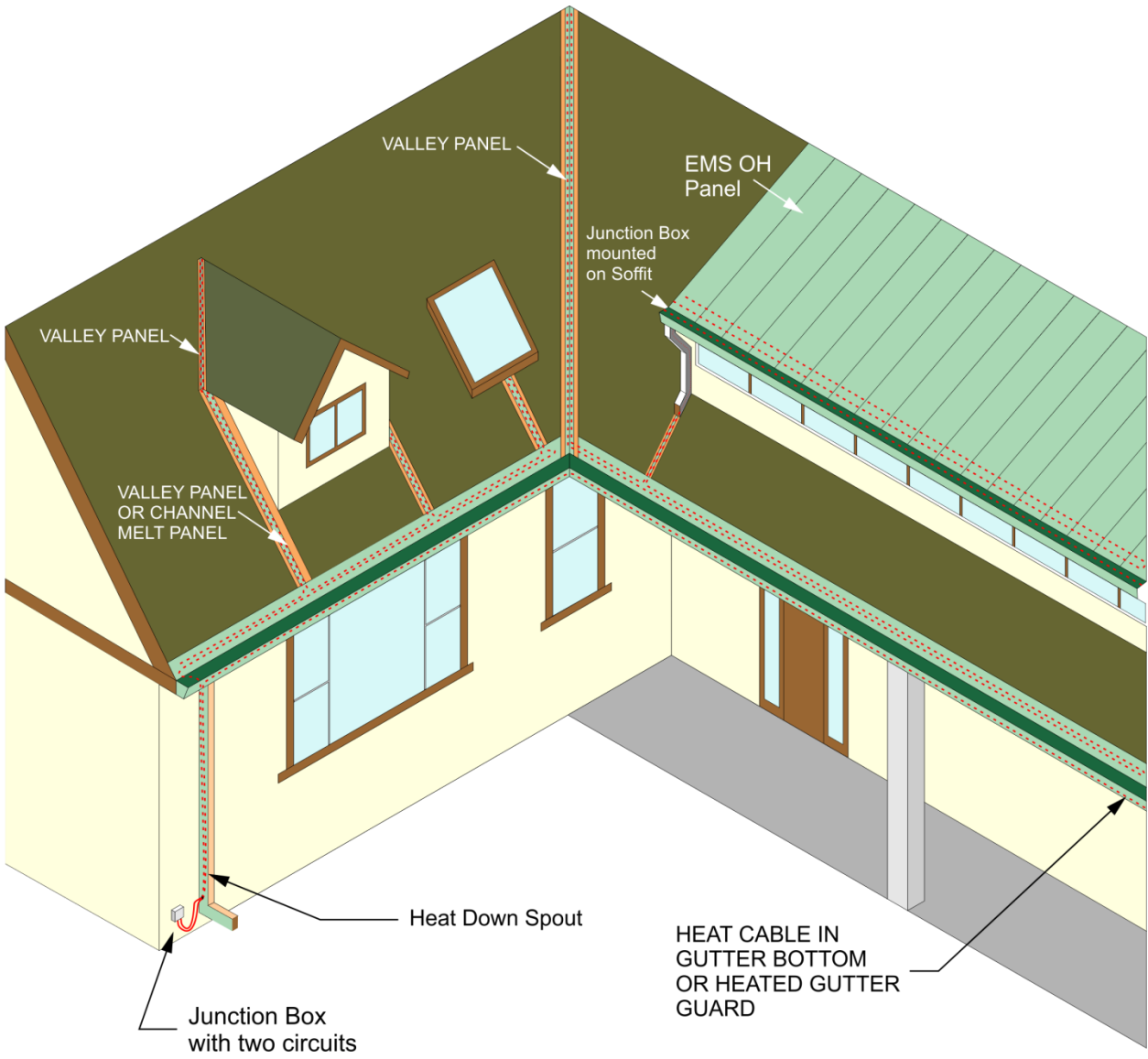

Installation

The DC-AS4 uses power from a separate 120V circuit (or panel outlet) to power the thermostatic controller. The system can have up to 4 separate branch circuits each rated at 30 amps, 110-277 VAC. These circuits must have ground fault protection with a 30 mA trip current as required by the NEC and the heat cable manufacturer. This is typically known as equipment ground fault protection.

Common installation problems are inadequate weather protection of exterior junction boxes and missing drip loops coming into the junction box as well as heat cables being damaged at installation.

The system requires temperature probe located in a shaded location or on the north side on the structure away from sources of heat such as furnace exhaust and solar gain. The temperature probe cable provided is 10'. It can be lengthened using 14AWG wire for runs to 300', 12AWG for runs to 400' and 10AWG for runs to 500'.

WiFi Control





Your DC-AS4 controller can have the control circuit remotely operated (turned on and off) by a home/business automation system or aftermarket WiFi switched outlet. Popular brands such as WeMo or SmartThings are examples of switched outlets. It is important that these devices receive a strong, consistent WiFi signal to ensure proper operation. We are not responsible for the suitability or functionality of any installed WiFi options. Please contact your installer or the manufacturer of the WiFi component for questions and trouble shooting. If your WiFi option can turn a lamp on or off, it can operate this controller.

These WiFi outlets can be coupled with WiFi based current sensing devices to confirm proper operation as well as remote cameras pointed at roof surfaces for the most efficient and reliable remote operation. This is especially helpful in remote locations where power loss is a common occurrence.

Using a switched outlet, install a plug whip (not supplied) on the 120V control circuit. Install your preferred WiFi outlet into the existing outlet and set up with your WiFi. You may need to install a booster or 'mesh system' to have a sufficient signal if you DC-AS4 controller is not installed near your WiFi signal source. Plug your DC-AS4 Controller into the WiFi outlet. The DC-AS4 controller can be left in the 'Man' or 'Auto' mode and turned on/off via the WiFi outlet.

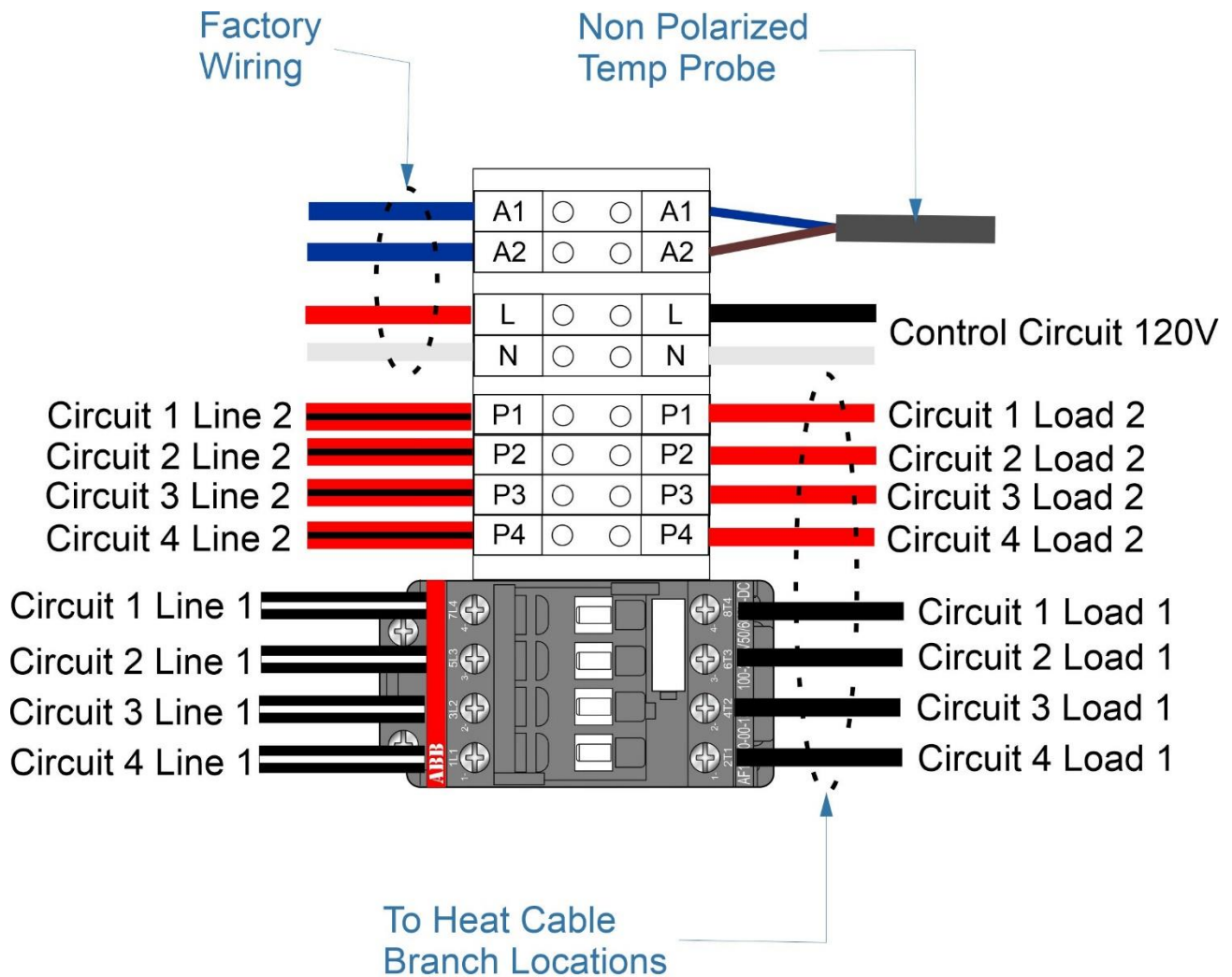
Field Wiring





 Denotes EPD protected circuit provided either by CB or field installed AC-EPD unit. In the case of AC-EPD, Load side (striped) should be connected to Line side of Controller. Wire nut incoming power to Line (solid) side of AC-EPD.

(See AC-EPD installation manual for further information)

Note: Line/Load 2 is N on 120V and 277V applications

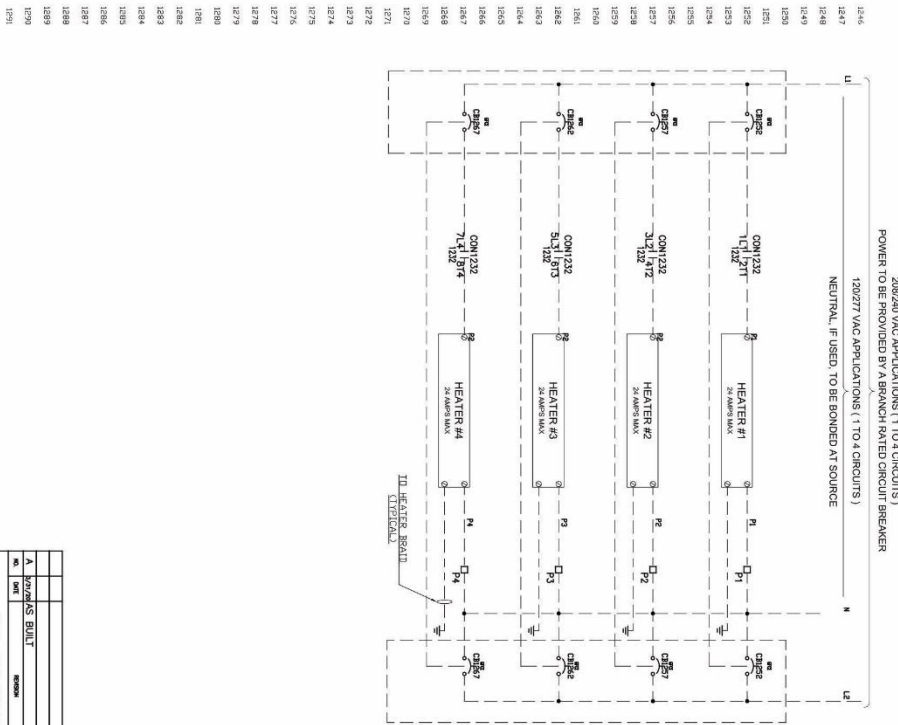
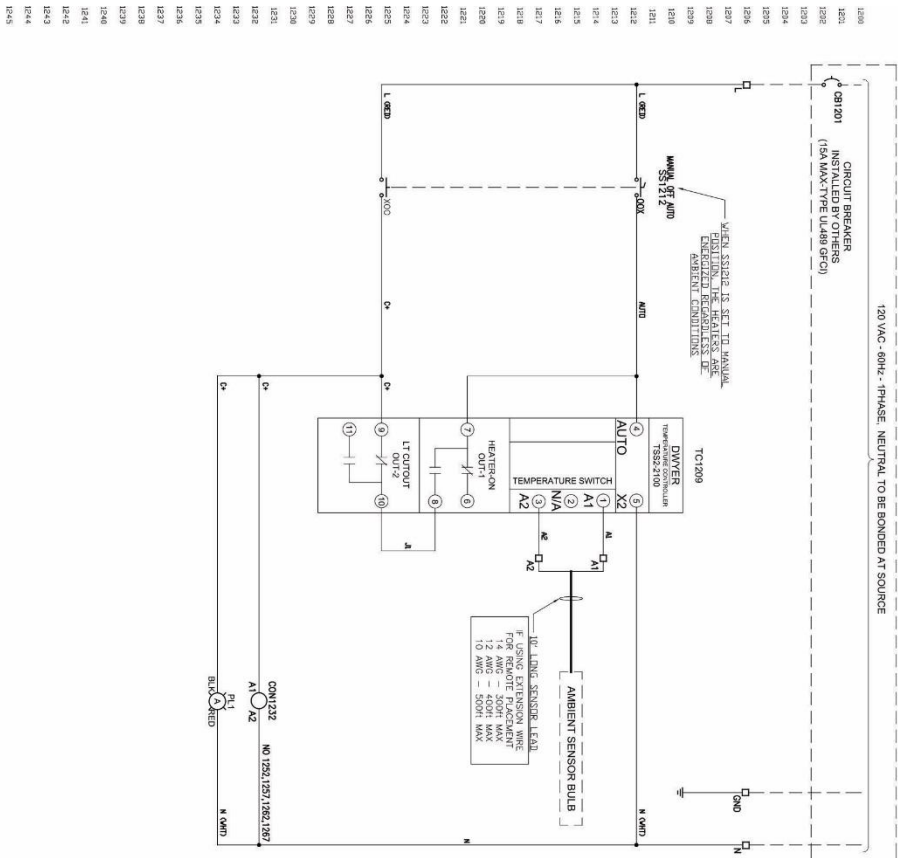
Wiring Diagram



NOTES:

- 1) DASHED LINES INDICATES A FIELD DEVICE OR FIELD WIRING.
- 2) SOLID LINES INDICATES WIRING INSIDE CONTROL.

NO.	DESCRIPTION	REV.	DATE
1	EDGES MELT SYSTEMS		
2	DC-AS4		
3	1-4 HEATERS		
4	SCHEMATIC		

Edge Melt Systems
DEARBORO, WISCONSIN 53015

REV.	DATE	BY	CHK.
1	12-01-20
2	12-01-20
3	12-01-20
4	12-01-20

Testing and Operation

1. Your heat cable system is designed to be preventative. This means it needs to be energized several hours prior to snow fall and should remain on while there is substantial snow on the roof. We will expand on this further in Section 4 – Seasonal Operation.
2. Your system is a hardwire system protected with ground fault equipment protection (EPD). This can be by the use of an EPD breaker or the AC-EPD from Edge Melt Systems. This means that if the cable is damaged the system will turn off by means of the EPD protecting the system. This provides safety for both the home or business and its occupants.
 - a. Damage can occur from tree branches falling on the structure, rodents (squirrels, chipmunks, and/or mice, etc.), other contractors working in the area of the heat cables, gutter cleaning, etc. Care should be taken to prevent this from happening.
 - b. Because your system uses an EPD, the system should be tested each fall to ensure no damage has occurred over the summer. This will be expanded on in Section 3.
3. **Preseason Testing.** Informational videos on Preseason Testing and Controller operation can be found at <https://www.youtube.com/user/NolceDams> or by typing Edge Melt Systems into the search bar on YouTube and look for our channel.
 - a. Preseason testing needs to be completed each fall to ensure the system will function for the coming season. It should not be assumed that the system will work just because it worked the prior year.
 - b. Preseason testing should be completed by October 15th of each year and any problems reported to the installing contractor by October 30th.
 - c. Testing your EPD for ground fault protection.
 - i. AC-EPD Unit (AC-EPD130 110/120VAC, AC-EPD230 220/240VAC, AC-EPD830 208VAC)
 1. Press the test button on the AC-EPD.
 2. The unit will pulse with a red LED light.
 3. Press Reset. There will be solid green LED light.
 4. Your system is now ready for use.
 5. If the red LED does not flash or come on, please call your installing electrician for assistance.
 - ii. EPD Breaker
 1. Have any control options in the off or stand by position.
 2. Press the test button on the EPD breaker(s) that feeds power to your heat cables.
 3. The breaker should ‘click’ into a tripped position. If it does not click into a tripped position, it is either OFF or already tripped.

4. Push the breaker all the way to 'off' and then back on. Some EPD breakers trip to a center position and you will not be able to turn the breaker back on until you reset fully to the OFF position and then to the on position. (If your breaker was in the OFF position and was not tripped by pushing the 'test' button, do that now and complete steps 1-4).
 5. Reset your breaker to the ON position.
- iii. Next, follow the appropriate control testing for the heat cables.
 - d. Testing Systems Controlled by a DC-AS4 Digital controller
 1. Confirm the breaker for the Control Circuit is in the on position.
 2. With your breaker in the on position, turn the controller to the 'Man'
 3. If your breaker holds and does not trip, your system is ready for winter.
 - a. You can now set your controller to the center or 'off' position until you are ready to operate.
 4. If your breaker trips, there is likely damage to the cable or moisture in the junction box or other location. Please contact the installing contractor for service.

4. Operating Systems Controlled by a DC-AS4 Digital Thermostat Controller.

1. Make sure that the breaker(s) for all the branch circuit(s) is in the ON position **AND** the EPD breaker or AC-EPD is in the ON position as well.
2. Systems need to be energized several hours prior to expected snowfall. This is done by setting the switch on the controller to the Auto or Man (or Manual) position. The center position on the switch is 'OFF'
 - a. 'Man' operation allows the controller to turn on the cables regardless of outside temps. It operates just like a switch.
 - b. 'Auto' operation reads the outside temps and turns the cables on based on the settings. Generally, the settings should be @ 39F (35F) degrees on the high side and @ 9F (5F) degrees on the low side. When temps are outside of that range, the controller will not send power to the heat cables. This will allow for the most efficient operation of your system ensuring it is warm enough to start melting snow as it is falling. There is a hysteresis on the temp settings allowing for the difference between rising and lowering temps.
3. The system should be left on while there is snow on the roof. This allows for the prevention of ice formation from melted snow. Snow can melt from temperatures fluctuating above and below freezing, heat loss from the home/business, and/or solar gain.
4. The system may be turned off using the switch on the controller while there is snow on the roof depending on how much melting is occurring. This is at your peril.

5. The system may be turned off when temperatures rise above 39 degrees (this allows for the slower warm up of roof and gutter surfaces) or is below 5 degrees (depending on the level of heat loss and snow build up on your roof). This is at your peril. Your DC-AS4 Digital controller will do this automatically if left in the 'Auto' position.
6. If your system is left off while snow and/or ice accumulates, it may clear once the system is turned on. This is entirely dependent on weather conditions. Failure of the system to recover entirely if the system is left off while snow and ice accumulate is the responsibility of the owner.
7. Systems may be turned off when no snow is on the roof. You must remember to turn the systems back on once snow is expected.

b. Snow Melting Expectations

- i. We design systems to be preventative based on annual averages. We do this to balance operating and installation costs with expected effectiveness.
- ii. Heavy Snow Fall/Blizzard
 1. It may be possible for snow to fall faster than your system can melt.
 2. There can be weather events that are far outside of these averages. This may be snowfall that occurs in heavy amounts over a short period of time or snow fall at temperatures at or below 5 degrees F. It may also be associated with blizzard type conditions resulting in heavy drifting.
 3. Your system will recover once conditions normalize. It is not uncommon for this to take several or more days and is controlled by the temperatures and winds after the event.
 4. Should greater melting capacity be desired, additional heat panels can be added.
- iii. Average snow falls
 1. Your system is designed to be preventative. This means that with average snow falls, it will keep the roof edges, valleys, and gutters free flowing while it is on. Valleys may appear snow covered while there is a tunnel underneath allowing for melted water to run off.
 2. Depending on your homes performance, it may be possible to turn the system off once the treated areas are clear of snow and ice. Care should be taken to not allow ice to build up as this will be more difficult to melt.
- iv. Windy conditions
 1. The windier it is, the more quickly heat can be wicked away from your system. This may result in the formation of small or minor icicles, especially at gutter edges. This is not a failure of the system.
 2. Systems are designed with energy consumption in mind. If these minor icicles are not acceptable, additional heating options can be considered.

- v. Secondary Ice Dam Formation
 - 1. Ice Dams can form higher on roofs. This result from various conditions.
 - a. Upper dormers
 - i. Dormers often do not have gutters and also form valleys that have uncontrolled run off. This can result in ice forming in areas not anticipated. It can also result in melt water refreezing at areas treated by the ice dam prevention system due to that area being overwhelmed.
 - ii. Should this be a problem, additional remedies can be taken such as adding heat panel systems in these areas along with gutters and downspouts.
 - b. Exhaust Vents
 - i. Exhaust vents can introduce unnatural melting by concentrating conditioned (warm) air in an area. The resulting melting can refreeze very close to the vent and result in leaking.
 - ii. Should this be a problem, additional remedies can be taken such as adding a heat panel to create a melt path the heated eaves or valleys.
 - c. Skylights
 - i. Skylights are a source of heat loss and the cause of melting and refreezing. Because they are often not near an eave, they are left untreated.
 - ii. Should this be a problem, these areas can be treated with additional heat panels to prevent the refreezing.
- vi. Annual Changes in Weather Patterns
 - 1. Our winters vary. One winter may be above average in temperatures or snow fall. The next may be colder or have less snow fall.
 - 2. We design for what the average is for the area.
 - a. We offer no guarantee what the weather will be for any given season.
 - b. We offer no guarantee that you will never have an ice dam or icicle.
 - i. We cannot control the weather. There may be a snow fall event that is far outside the normal along with severe and prolonged below zero-degree temperatures.
 - ii. We cannot control when you have your system on or off.
 - iii. We have a proven track record of designing and installing systems that prevent ice dams.
 - iv. We can design a 'tiered' system. This will allow for additional heat cables to be turned on for extreme

winter events. This may require additional circuits and heat panels as well as further electrical requirements.

1. When not needed for normal winter functioning, these extra cables can be turned off.

5. Trouble Shooting Your Heat Cable System

- a. Your system does not appear to be on or melting anything.
 - i. Check that the circuit breaker controlling the heat cables is truly in the ON position. Tripped breakers can appear on when they have not been reset. Reset the breaker by turning it all the way OFF and then to the ON position.
 - ii. Check that all controlling switches or thermostat controllers are ON and functioning.
 - iii. Check that the ambient temperature is not currently outside of any trigger temperatures for your controller.
 1. These trigger temps can be adjusted on the DC-AS Digital Controller.
- b. The EPD circuit breaker keeps tripping when you try to reset it.
 - i. There is some physical damage to your heat cable or moisture intrusion. The circuit breaker is performing its designed function.
 - ii. Contact your installing contractor.
- c. The DC-AS Digital indoor controller will not turn on.
 - i. Check that the circuit breaker controlling the unit is ON.
 - ii. Check that you have turned the switch to the 'Man' or 'manual' position. Only the light at the center will light up if the controller is in the 'Man' position – no temperature indications will display.

Temperature Controller Programming

The Temperature Controller is shipped preconfigured so that further programming is not required. Temperature probes do need to be calibrated and occasionally small adjustments may be made to the turn on or turn off set point temperatures.

The operational concept is that above 38°F snow will melt without applying heat. Below 5°F snow will not melt if no heat is applied and can remain in this state until the outdoor temperature rises above 9 F. At that point, the controller re-energizes the heat cable system.

The Temperature Controller is configured for relay 1 to turn on the heat cables when outdoor temps fall below 35°F and off when above 39°F. Relay 2 is programmed to turn off the heat cables 5°F and setup to resume operation when the temperature rises above 9°F.